

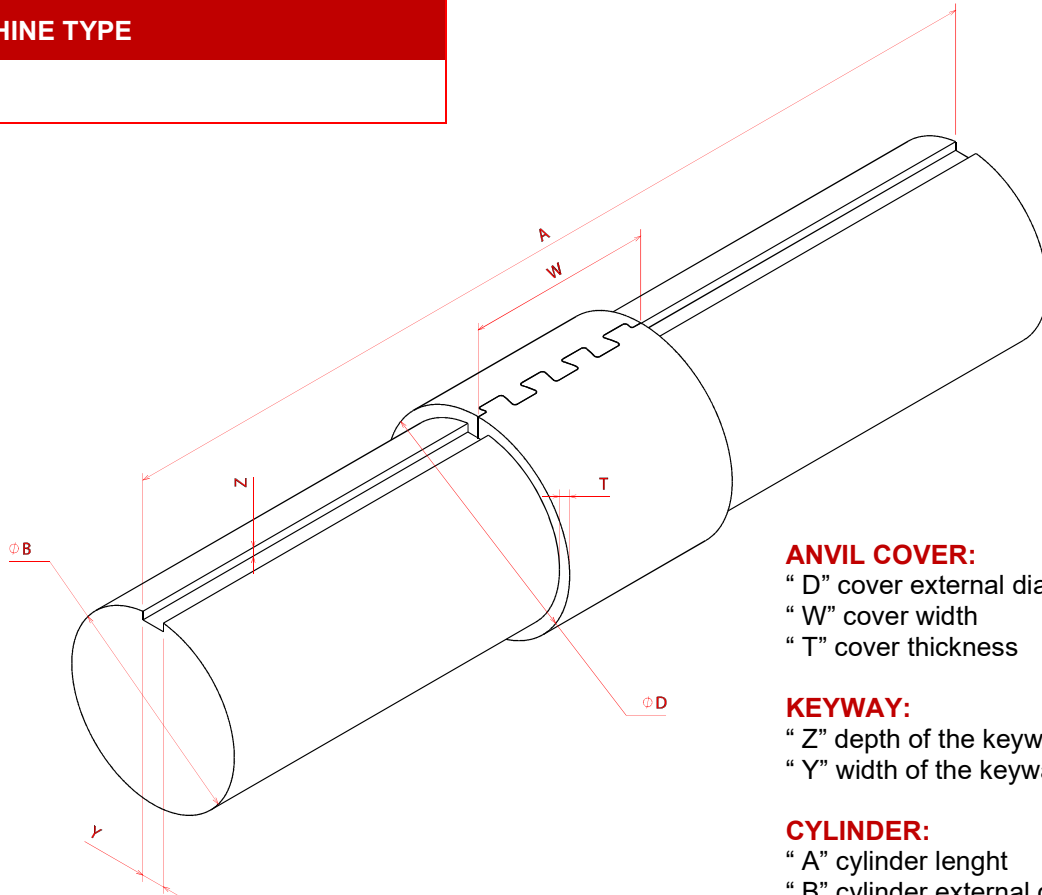

COMPANY NAME	
ADDRESS	
CONTACT PERSON	

MACHINE TYPE



ANVIL COVER:
 “ D ” cover external diameter
 “ W ” cover width
 “ T ” cover thickness

KEYWAY:
 “ Z ” depth of the keyway
 “ Y ” width of the keyway

CYLINDER:
 “ A ” cylinder length
 “ B ” cylinder external diameter

	mm
D cover external diameter	
W cover width	
T cover thickness	
Z depth of the keyway	
Y width of the keyway	
B cylinder external diameter	
cylinder length	

Existing Blanket/Anvil Part number		
Equalizer ?	Yes	No

